

Avax D100 Drop Arm / Double Tripod Turnstile



Avax D100 Drop Arm Turnstile allows both entries and exits at the same time. Thanks to the Emergency Dropping Arm feature in both directions, it provides fast and safe evacuation by going down in case of a power failure, signal from the fire alarm system or emergency situations. With the Emergency Button connection you can release all passes. Button connection can be made for guest or VIP passes. By connecting the counter on the turnstile, the total number of passes per day can be obtained.

Devices such as fingerprint, face recognition, card reader can be connected to the entrance and exit sides and can run in harmony with the cafeteria, access control, pdks programmes.

The card reading device is built in the internal reading sections on the turnstile for an ergonomic and stylish appearance. It runs fully compatible with all Face recognition, Fingerprint recognition, Card recognition and Password devices with short circuit (Dry contact) feature .

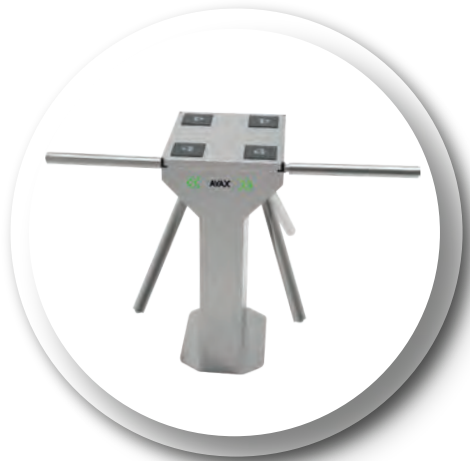

Technical Specifications

Body	AISI 304 quality stainless steel
Arms	AISI 304 quality stainless steel
Passing Distance	50-55cm
Tripod Lockout	Allows passing only when the solenoid is pulled
Emergency Dropping Arm	In case of power failure, signal from the fire alarm system or emergency, provides rapid evacuation by going down
Direction of Passing	It can be adjusted as Entry only, Exit only, or passing from both directions as desired
Passing Time	Adjustable as required
Warning for pass	Provides visual and audible warnings
Passing Information	NC: Normally closed or NO: Normally open
Passing Speed	~ 70 people / minute
Passing Control	When one direction of rotation starts, the reverse direction is prevented and cannot be reversed after half rotation occurs.
Operating voltage	100/240 V
Power consumption	35 W
Frequency	50-60 Hz
Area of Use	Indoor and Outdoor
Operating temperature	-25 to +70 Degrees
Test Result	Tested 3 Million passes
Weight	Approx. 52 kg
Installed Dimensions	500x 450 x 980 mm (without arms)
Access Control	It can run together combined with Fingerprint, face recognition, vein recognition and card readers by receiving the signal.
Certifications	ISO, CE and Warranty certificate

Technical Drawing

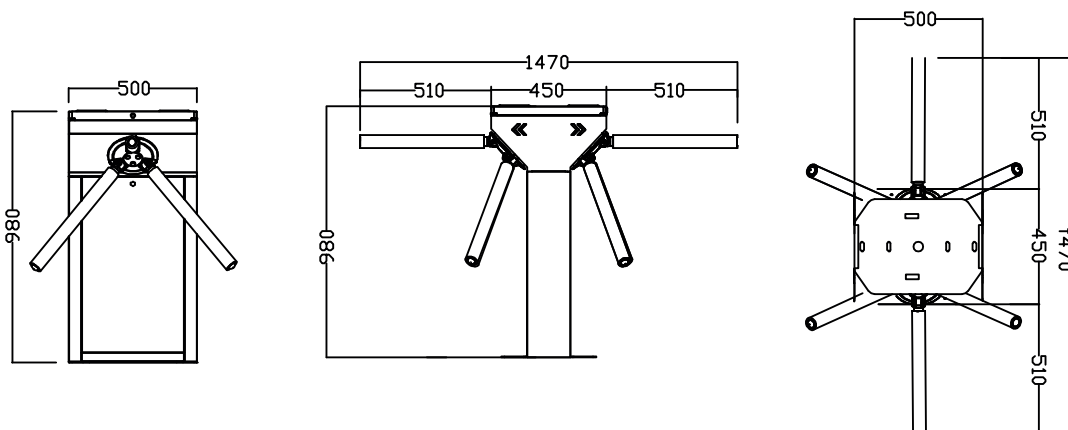

Benefits



Arms with inner and outer parts are made of 304 quality stainless steel and are durable and long lasting.

Patented lubrication system minimizes the need for maintenance.

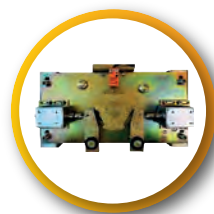

In case of power failure and emergency, the arm will automatically fall down, allowing you to pass quickly and without obstacles.

It has high quality PCB and electronic components. Runs without being affected by environmental electro-magnetic noise

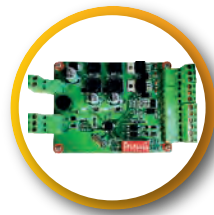

Ergonomic plexy design facilitates face recognition, fingerprint reading and card reader installation.

It eliminates confusion by guiding with bright LED signs in the direction of passing



Ideal for indoor and outdoor use.

Since it can be mounted at two points on the ground, turnstile runs without shaking during the passes.



Usage areas

- ✓ Factories
- ✓ Hospitals
- ✓ Business centers
- ✓ Dining Halls
- ✓ Airports
- ✓ Logistics Areas
- ✓ Academies
- ✓ Gyms
- ✓ Public institutions
- ✓ Chain Stores
- ✓ Hotels
- ✓ Activity Areas
- ✓ Plazas
- ✓ Residences
- ✓ Military Areas
- ✓ Fair Entries
- ✓ Smart Buildings
- ✓ Dams
- ✓ Shopping malls
- ✓ Public Transport Stations



SISTEMAS BYACCESS, S.L.
C/ Puente de Madrid, 28
28412 - Cerceda - Madrid - SPAIN
Tel: +34 918 420 129
Info@byaccess.com
byaccess.com



Sistemas Seguridad.com

sistemas-seguridad.com

