



## SBTL3000 Series

**SBTL3000** Single Lane Swing Barrier Turnstile

**SBTL3011** Single Lane Swing Barrier Turnstile  
(w/ controller and RFID reader)

**SBTL3022** Single Lane Swing Barrier Turnstile  
(w/ controller and fingerprint & RFID reader)

The SBTL3000 single lane swing barrier turnstile is an elegant cost-effective entrance control system designed for high-traffic volume.

The SBTL3000 is a single lane swing barrier turnstile series designed for smooth and silent operation and draws very little power. It's made of stainless steel which makes SBTL3000 highly durable.

SBTL3000 barriers are normally held in a locked position, thus denying access to the secured side. Upon SBTL3000's reader (RFID and/or fingerprint) positively recognizing a user's valid access card or fingerprint, its barriers swing automatically, thus allowing users passage to the secured side.

During emergencies the barriers automatically swing, thereby ensuring users FAST unencumbered exit to safety. During power outage, the user can push through the barrier easily to exit to safety.

SBTL3000 provides both security and convenient space, all in a very durable and elegant compact design.

### Features

#### Reliability

- SUS304 stainless steel casework ensure long-lasting durability
- High quality electrical components Safety Features.
- Barriers swing automatically during emergencies
- All smooth finish. No exposed screws.
- Ergonomic design makes card and fingerprint authentication fast & simple for users.

#### Built-in Reader Integration

- SBTL3000 series ships already integrated with our customers' preference for either card or fingerprint access control reader. This greatly reduces installation time & expense.
- SBTL3000 series and associated access control readers are all factory-tested prior to shipping.
- ZKTeco provides true plug & play turnstiles with the lowest possible total cost of ownership in the industry.

#### Simplification

- Simplify structure and connection, easy to maintain.
- LCD display screen shows the current running status, easy operation.

# Specifications

Power requirements	AC110V/220v,50/60HZ	
Working temperature	-28°C~60°C	
Working humidity	5%~80%	
Working environment	Indoor/Outdoor	
Speed of throughput	RFID	Maximum 30/ minute
	Fingerprint	Maximum 25/ minute
Lane width(mm)	1050	
Footprint(mm*mm)	1570*1500	
Dimensions(mm)	L=1500,W=260,H=1000	
Dimension with packing(mm)	L=1640,W=760,H=1100	
Net weight(kg)	114	
Weight with packing(kg)	161	
LED indicator	Y	
Cabinet material	SUS304 Stainless Steel	
Lid material	SUS304 Stainless Steel	
Barrier material	SUS304 Stainless Steel	
Barrier movement	Swing	
Emergency mode	Y	
Security level	Medium	
MCBF	2 million	



## Dimensions (mm)

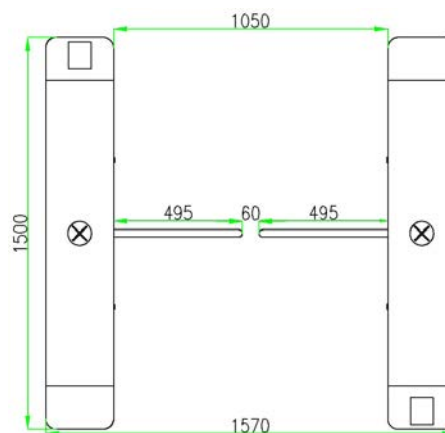
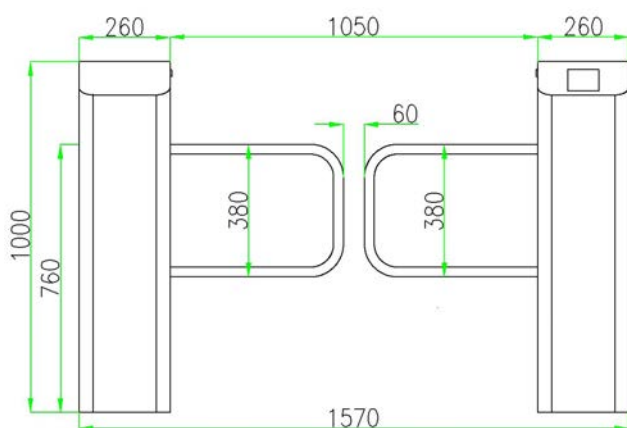

**SISTEMAS BYACCESS, S.L.**  
 C/ Puente de Madrid, 28  
 28412 - Cerceda - Madrid - SPAIN  
 Tel: +34 918 420 129  
 Info@byaccess.com  
 www.byaccess.com



**Sistemas Seguridad.com**

Sistemas-seguridad.com

